

Wichtig: Wenn Sie kein ausgebildeter Mechaniker sind, wenden Sie sich bitte an eine Fachwerkstatt!

Bitte vor der Montage beachten!

Die Montage der Crash Pads muss seitenweise erfolgen!

Das gleichzeitige Lösen der beiden Motorhalteschrauben ist zu vermeiden!

Anzugsdrehmomente Schrauben M10x85 lt. Fahrzeugherstellerangaben!

Anbau der rechten Seite

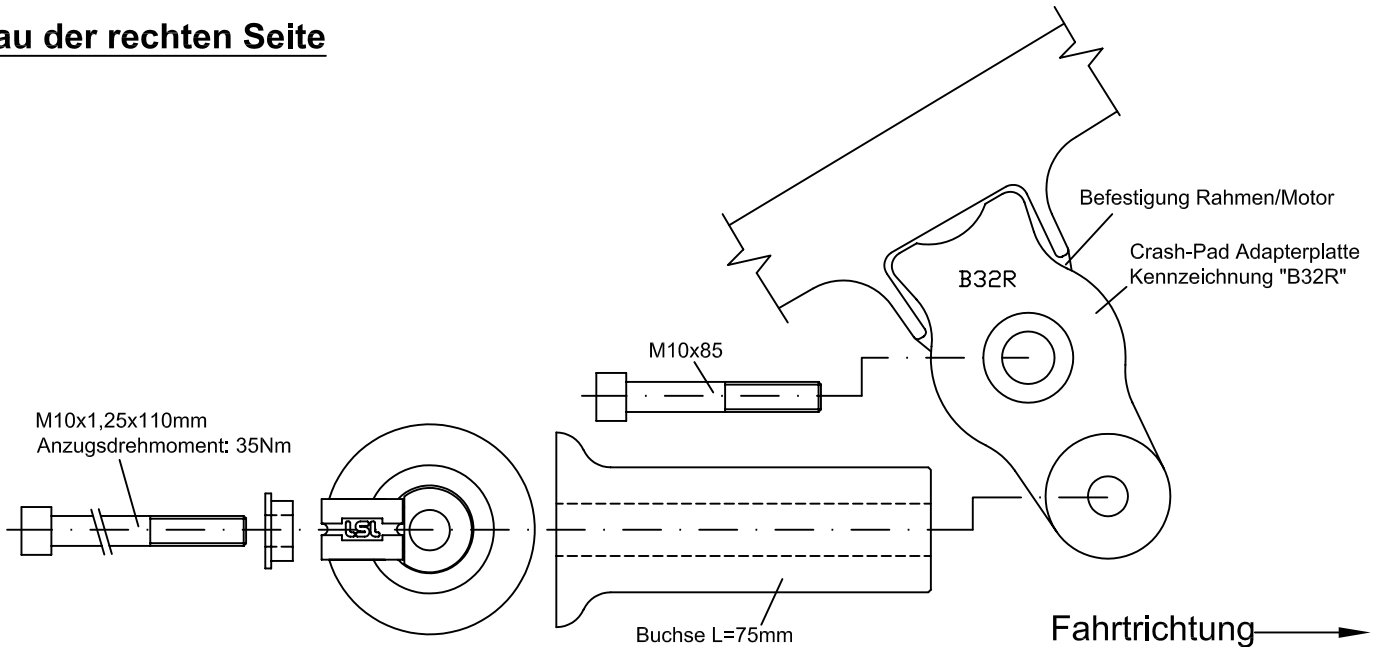

Anbau der linken Seite

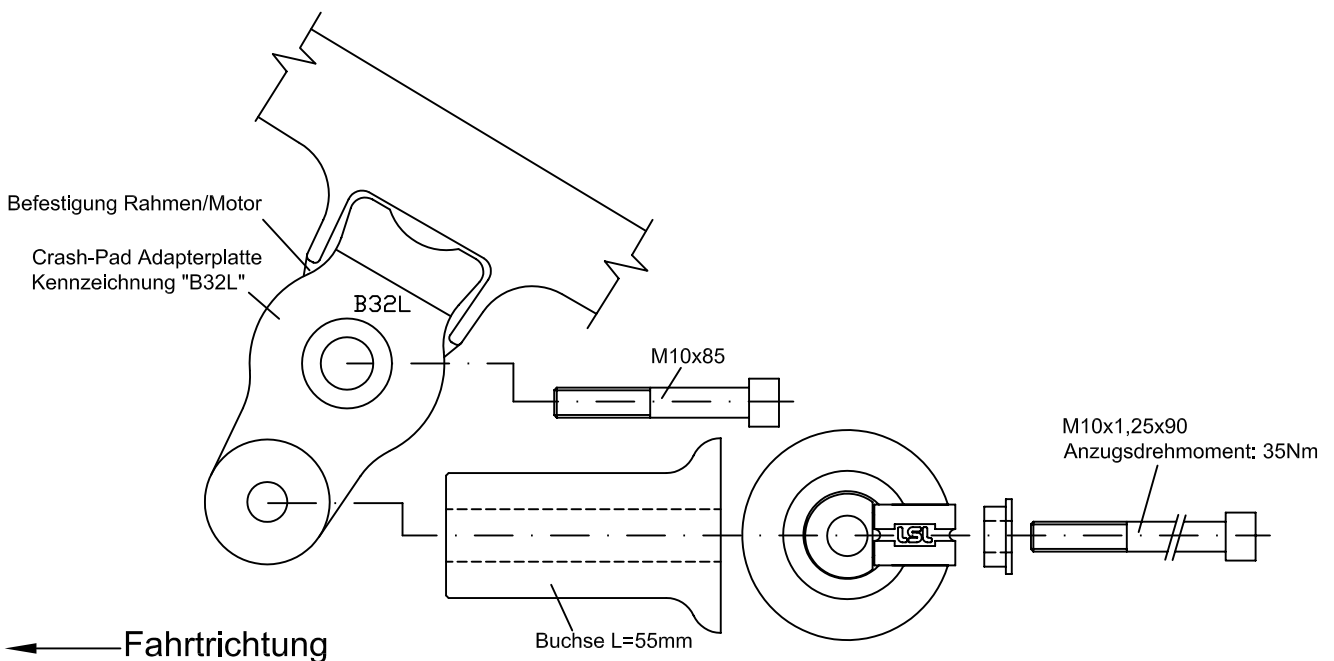

D – 47809 Krefeld

www.lsl-motorradtechnik.de

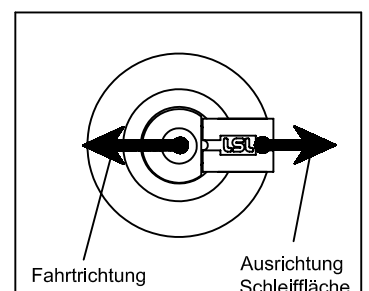

Important: If you are not a trained motorcycle mechanic stop now. Ask a local motorcycle shop to do the work for you!

Please take extra care!

You have to mount the crash pads one side after the other!

Do not loose more than one engine bolt at the same time!

For tightening torques of the engine bolts M10x85 look at the work shop manual!

Fitting on the right side

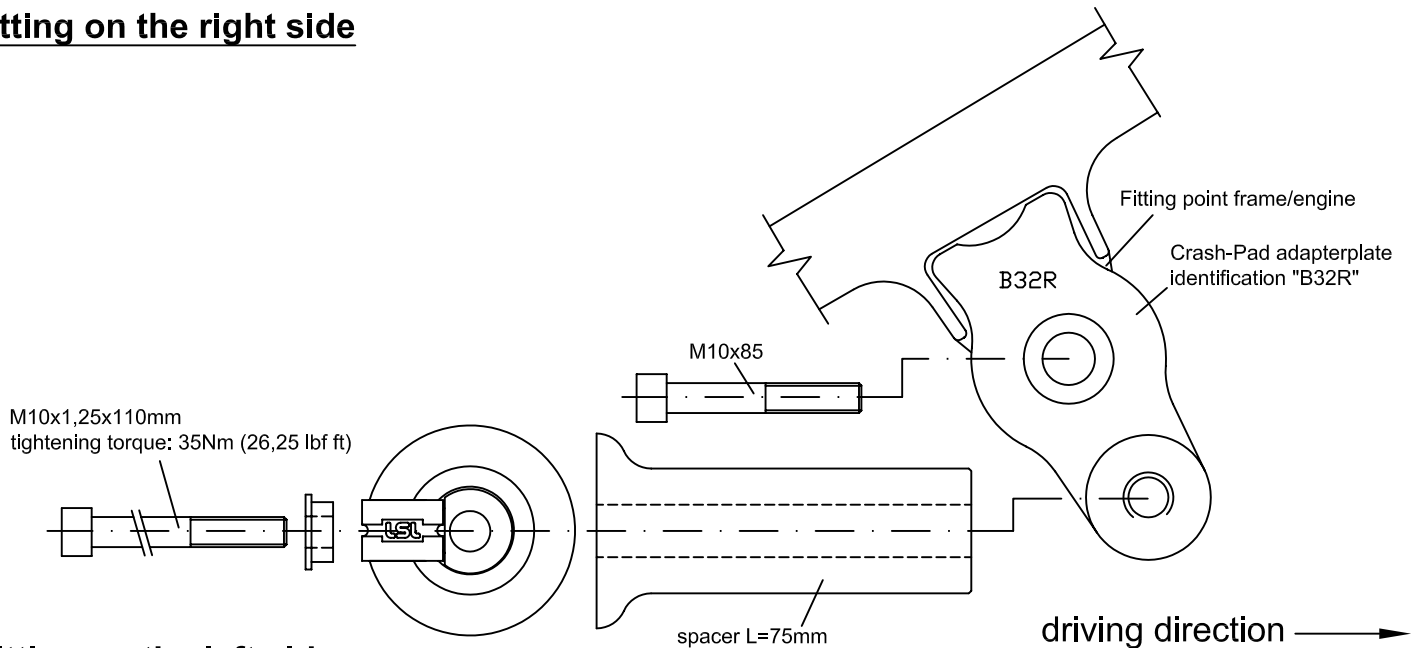

Fitting on the left side

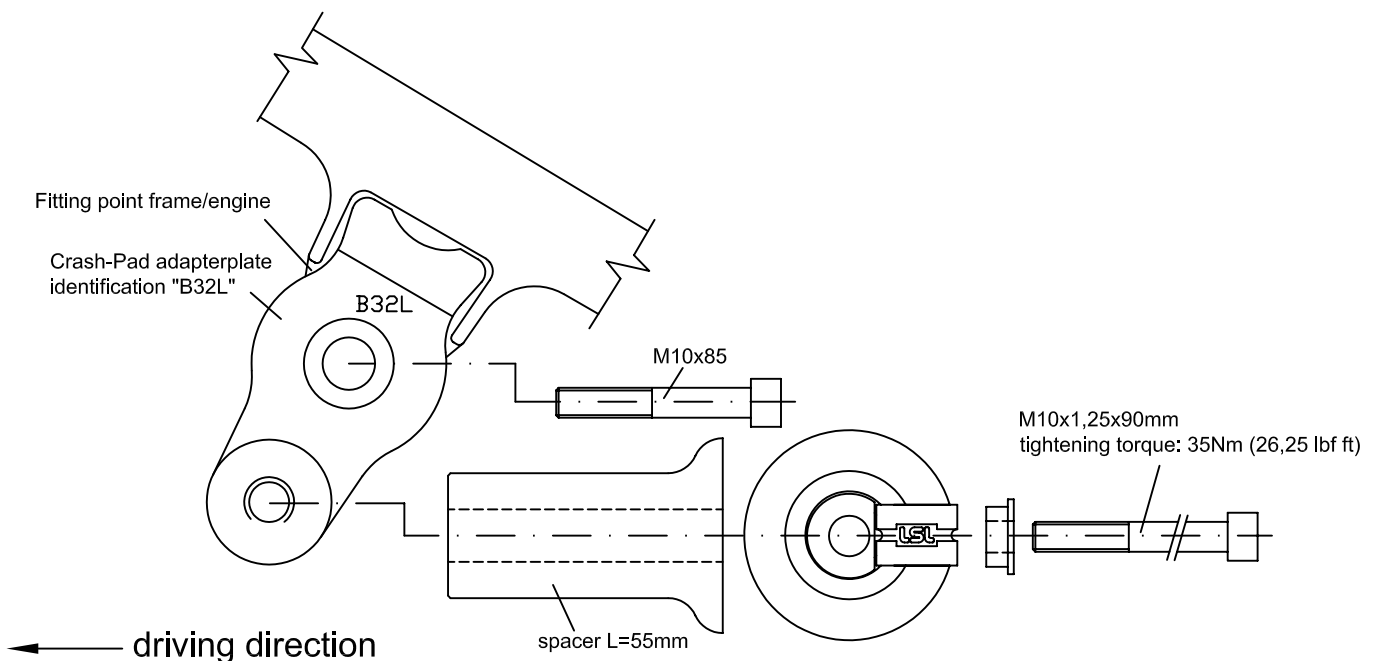

D – 47809 Krefeld

www.lsl-motorradtechnik.de

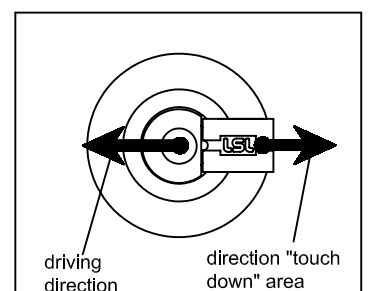

Instructions de montage des Crash-Pads pour BMW F800S

N° article : 550B032

Important: Le montage doit être fait par un professionnel!

Le montage des Crash-Pads s'effectue d'abord d'un côté et ensuite de l'autre! Il faut éviter le desserrage simultané des deux vis tenant le moteur!

Utilisez les couples de serrage préconisés par le constructeur!

Le carénage reste inchangé!

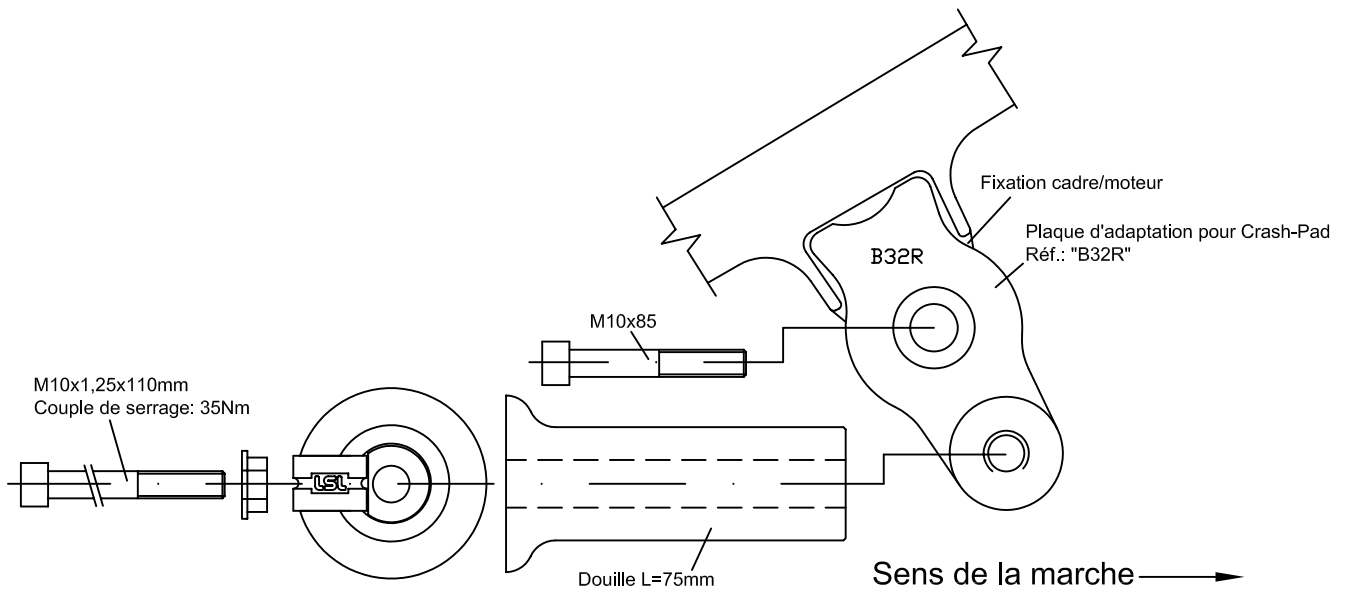

Montage côté gauche:

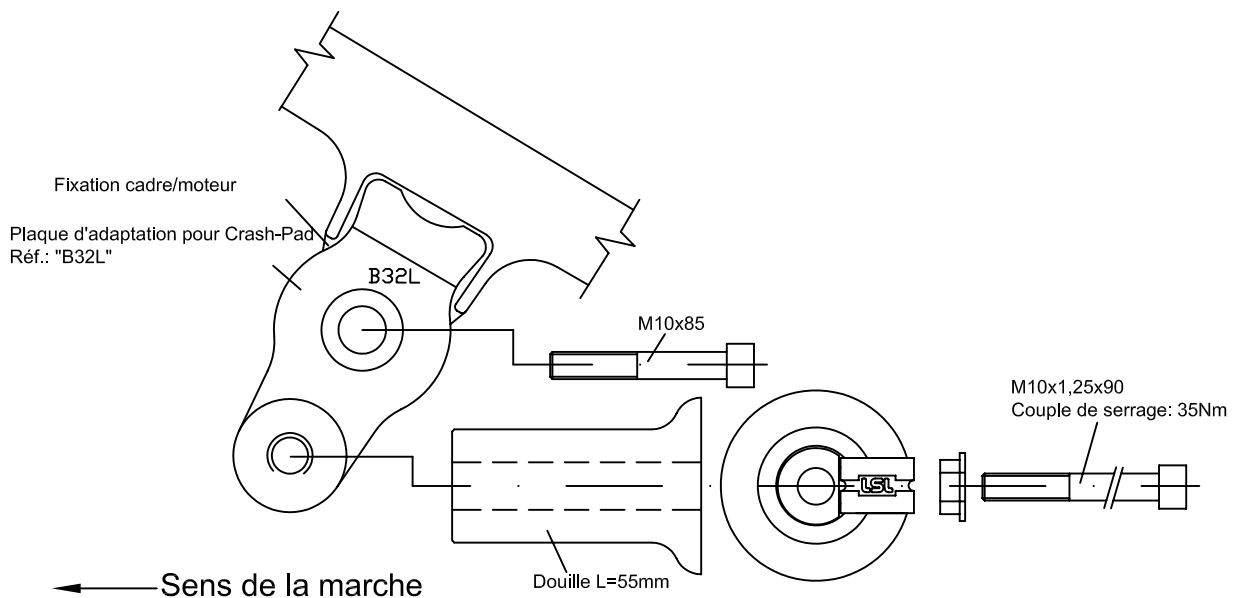

LSL-Motorradtechnik GmbH • D-47809 Krefeld

www.lsl.eu

Stand:07.05.2007

