

Wichtig: Wenn Sie kein ausgebildeter Mechaniker sind, wenden Sie sich bitte an eine Fachwerkstatt.

Bitte unbedingt vor dem Anbau beachten!

Die Montage der Crash-Pads muss seitenweise erfolgen!

Das gleichzeitige Lösen der beiden Motorhalteschrauben ist zu vermeiden!

Anzugsdrehmomente Motorbefestigungsschraube lt. Herstellerangaben!

Anbau der rechten Seite

(Ansicht von hinten)

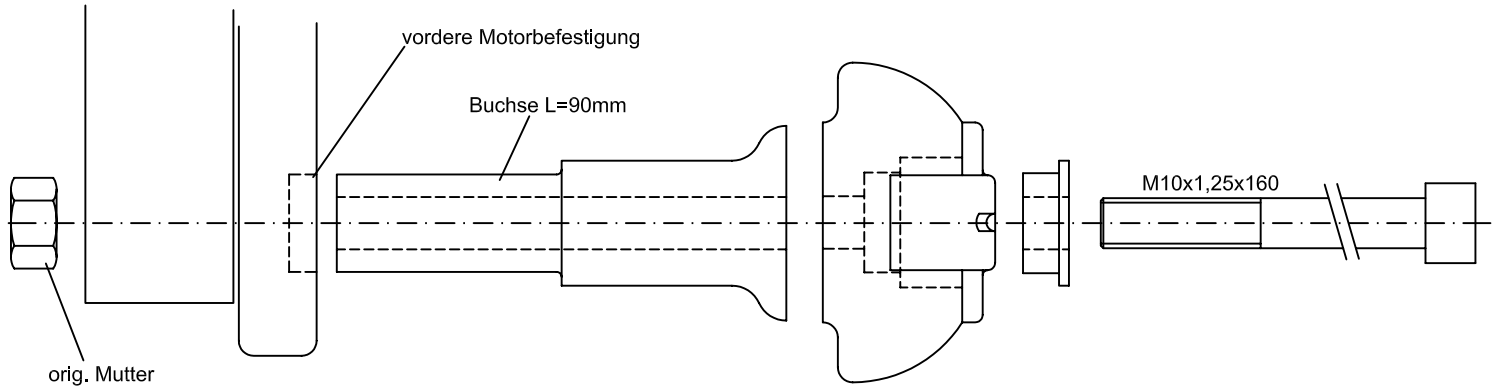

Anbau der linken Seite

(Ansicht von hinten)

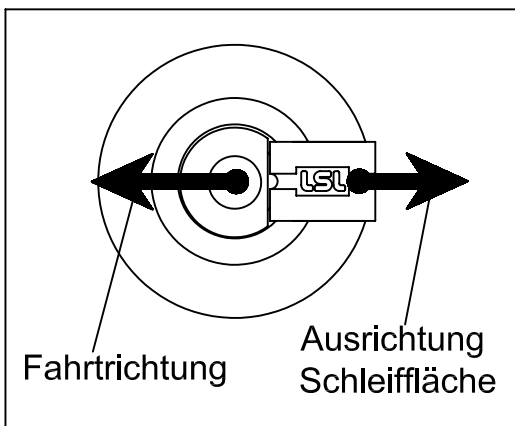
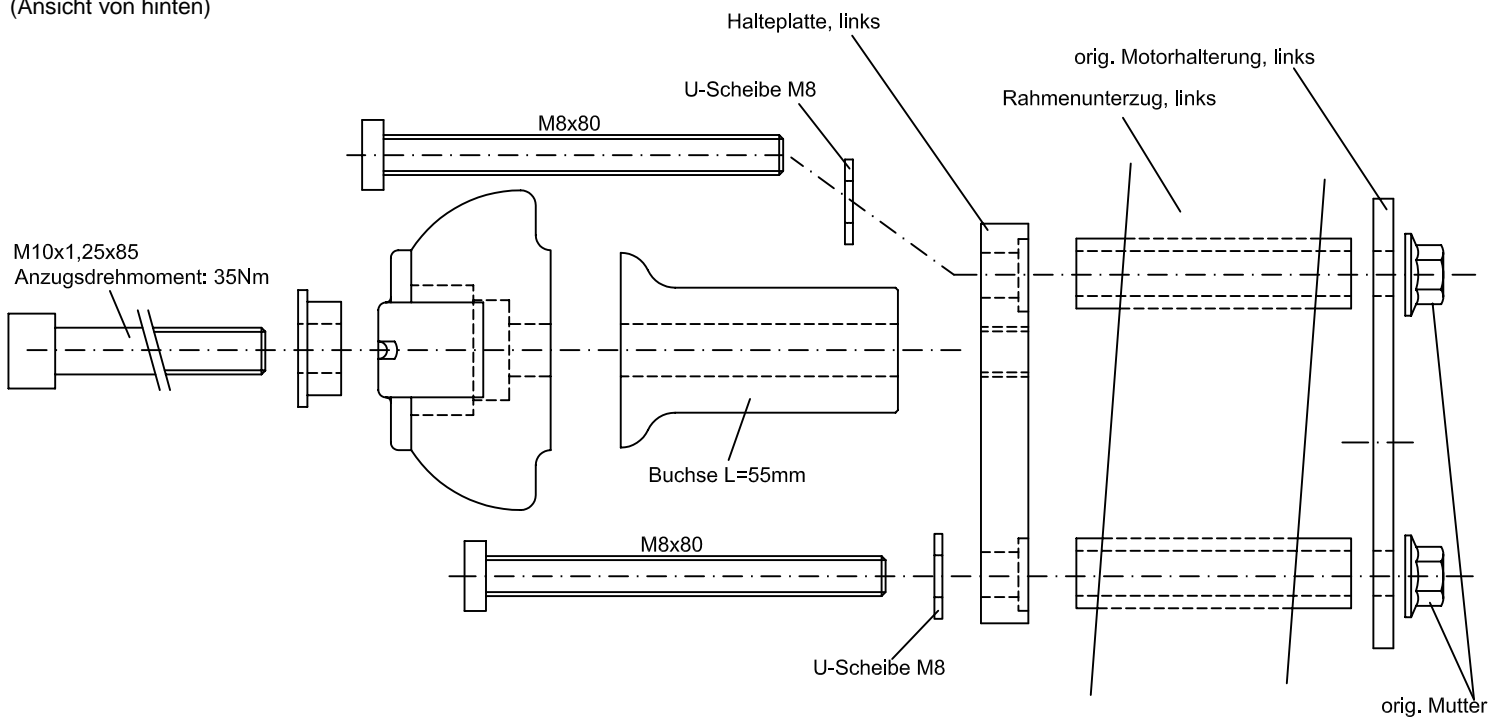

Paaschburg & Wunderlich GmbH · D-21509
www.lsl.eu

Fitting instruction Crash-Pads Kawasaki ZRX 1100 & ZRX 1200/S/R Part.no.: 550K096

Important: If you are not a trained motorcycle mechanic stop now. Ask a local motorcycle shop to do the work for you.

Please take extra care!

You have to mount the crash-pads one side after the other! Do not loose more then one engine mounting bolt at the same time!

The tightening torques refer to the manufacturer's instructions!

Fitting on the right side

(view from rear)

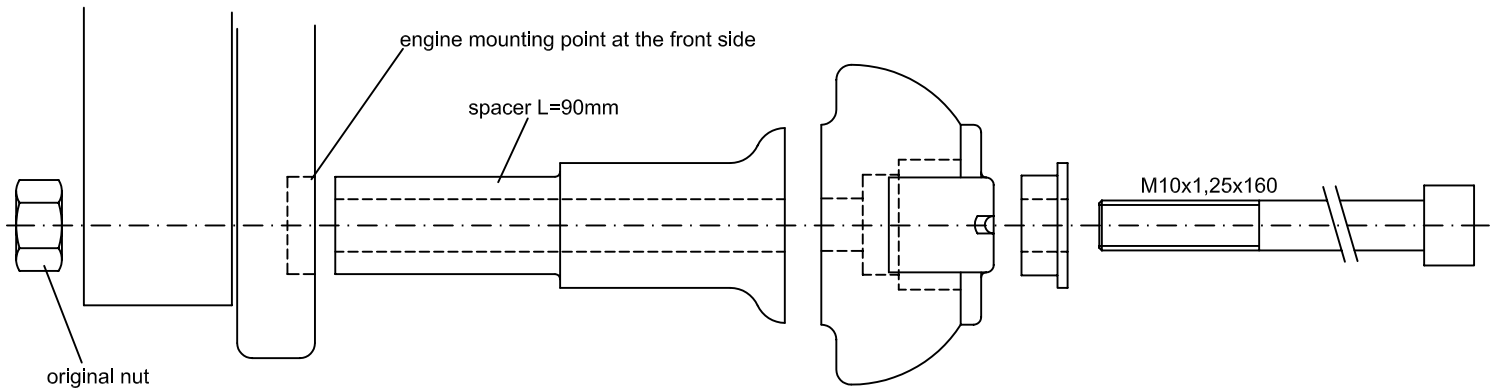

Fitting on the left side

(view from rear)

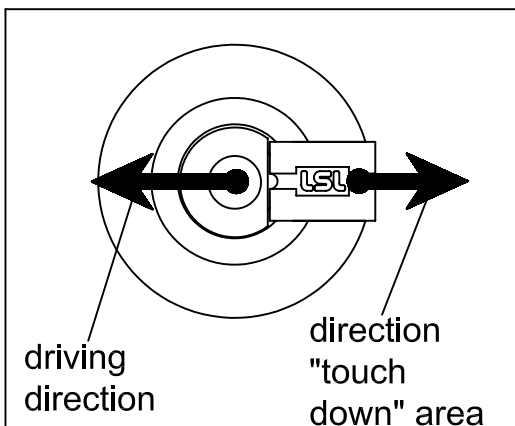
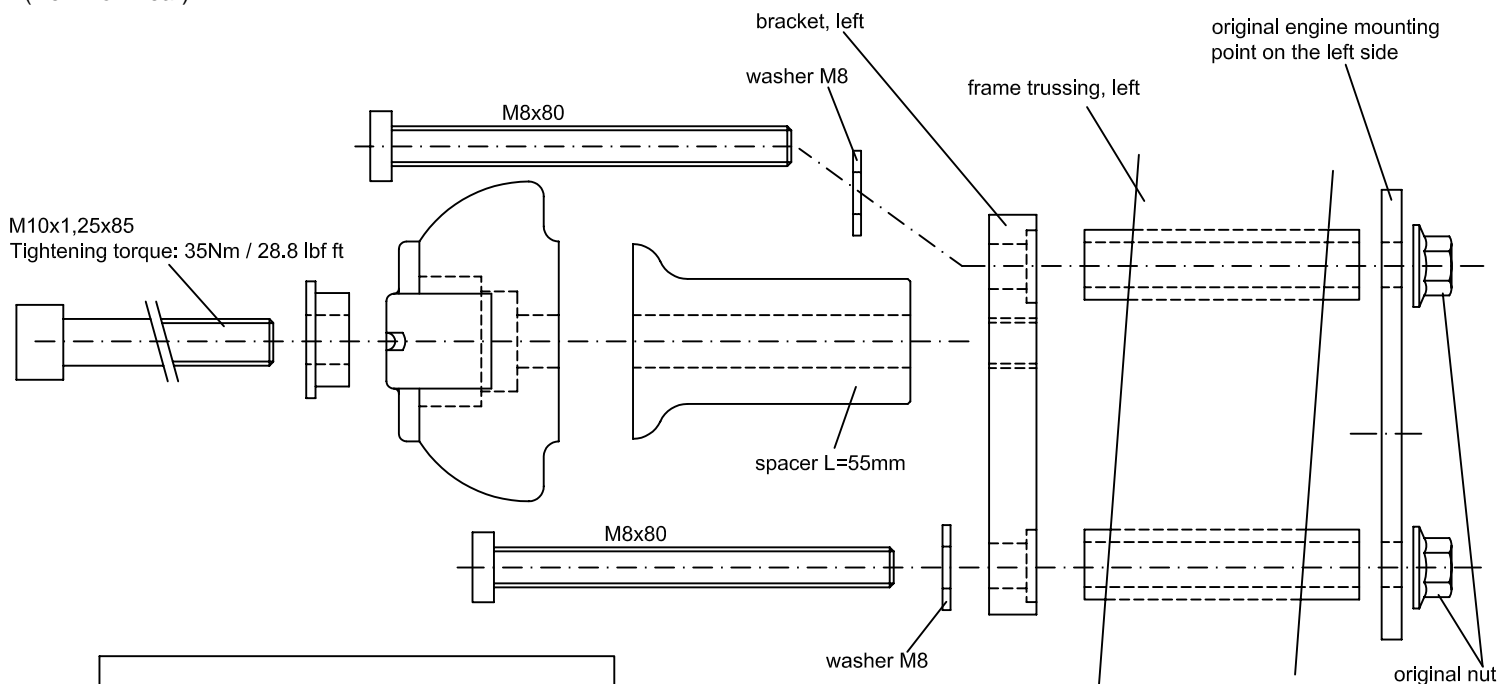

Paaschburg & Wunderlich GmbH · D-21509
www.lsl.eu

Instructions de montage des Crash-Pads pour ZRX 1100 & ZRX 1200/S/R

N° article : 550K096

Important: Le montage doit être fait par un professionnel!
Le montage des Crash-Pads s`effectue d`abord d`un côté et ensuite de l`autre! Il faut éviter le desserrage simultané des deux vis tenant le moteur!
Utilisez les couples de serrage préconisés par le constructeur!

Montage côté droit:

(Vue arrière)

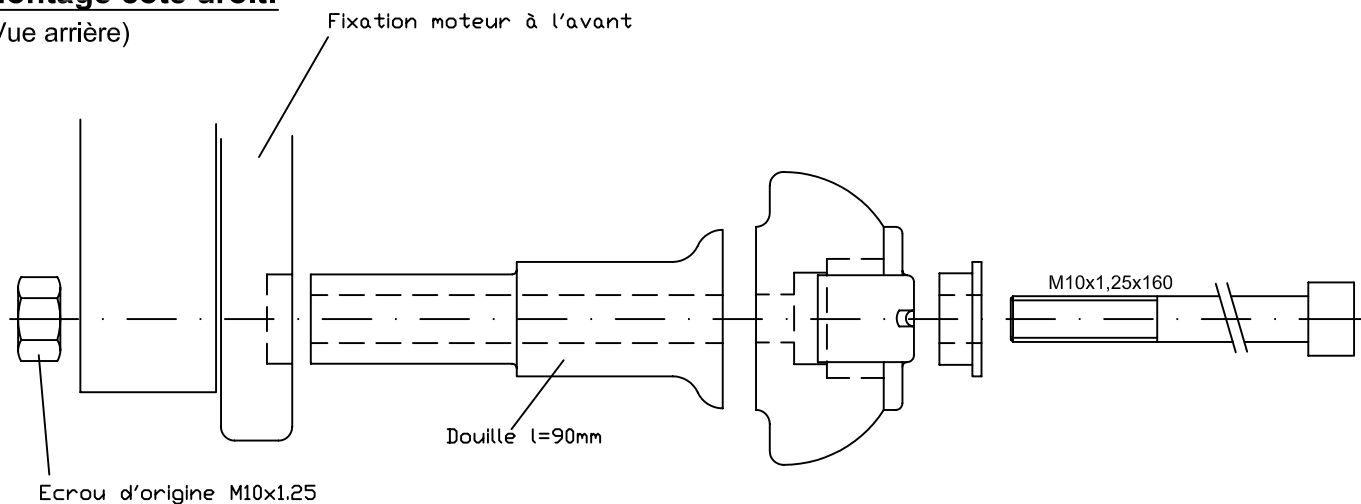

Montage côté gauche:

(Vue arrière)

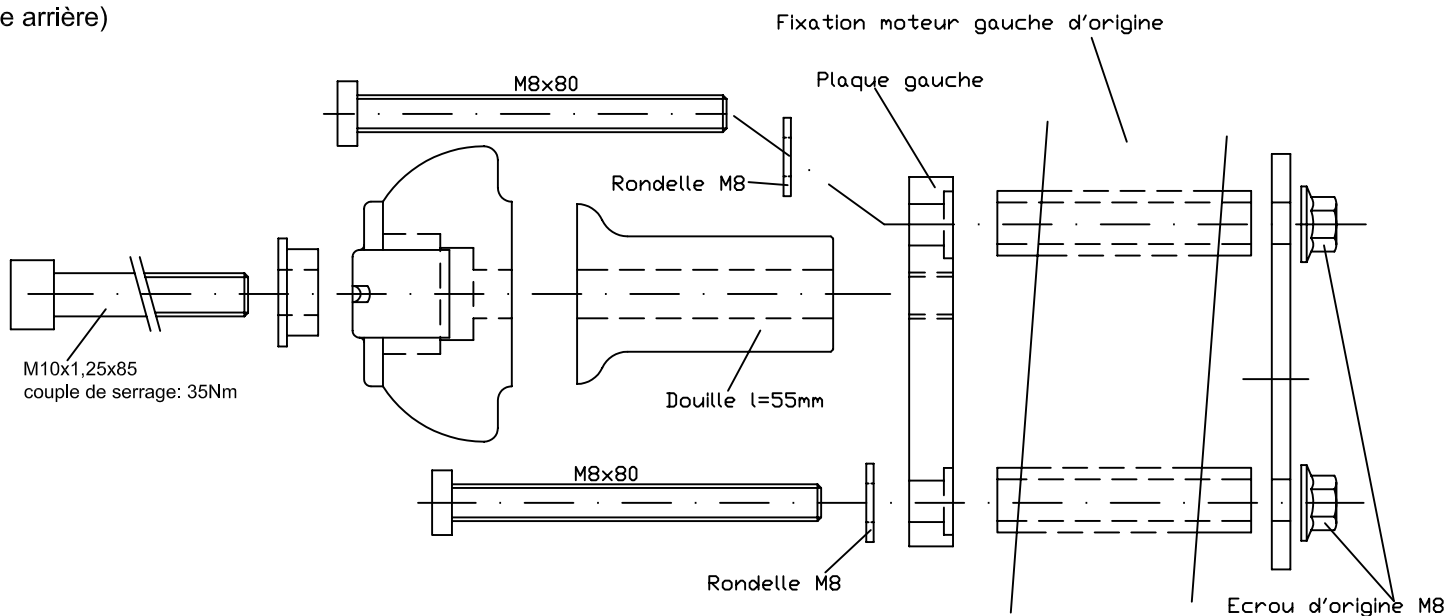

Paaschburg & Wunderlich GmbH · D-21509
www.lsl.eu

Rev. 02 08/06/2009

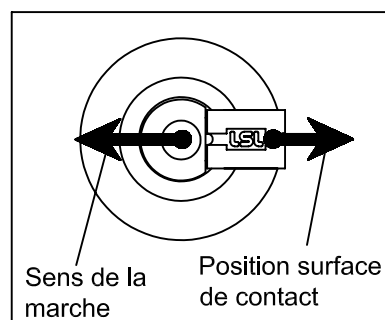



MAKING GOOD BIKES PERFECT

Paaschburg & Wunderlich GmbH · D-21509
www.lsl.eu