

Hinweis: Montieren Sie die Crash Balls in die Vorderachse mit dem Anzugsdrehmoment von 10Nm. Kontrollieren Sie in regelmäßigen Abständen den festen Halt der Crash Balls!

Anbau vorne links

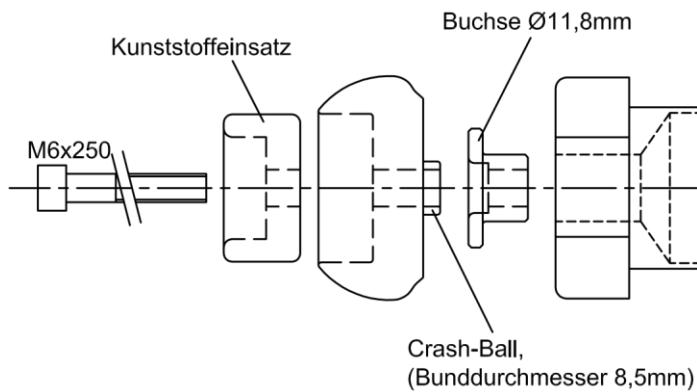

Anbau vorne rechts

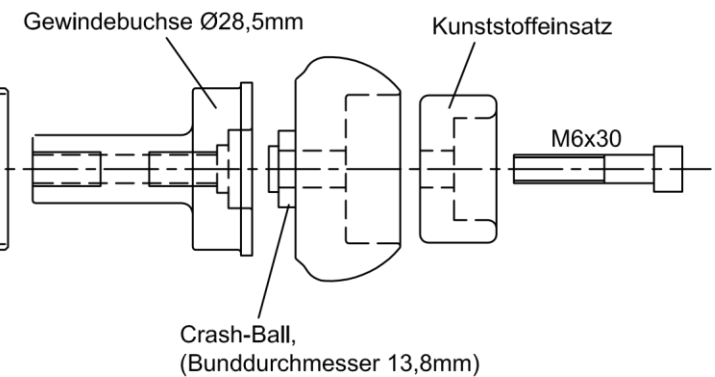

LSL-Motorradtechnik GmbH • D-47809 Krefeld

www.lsl.eu

Stand: 10.05.2007

Note: Check the Crash Balls for proper fit a few days after first installation, then periodically every 3 month. Tighten them again if necessary.

The tightening torque is 10Nm / 7.37lbf ft.

Fitting left

Fitting right

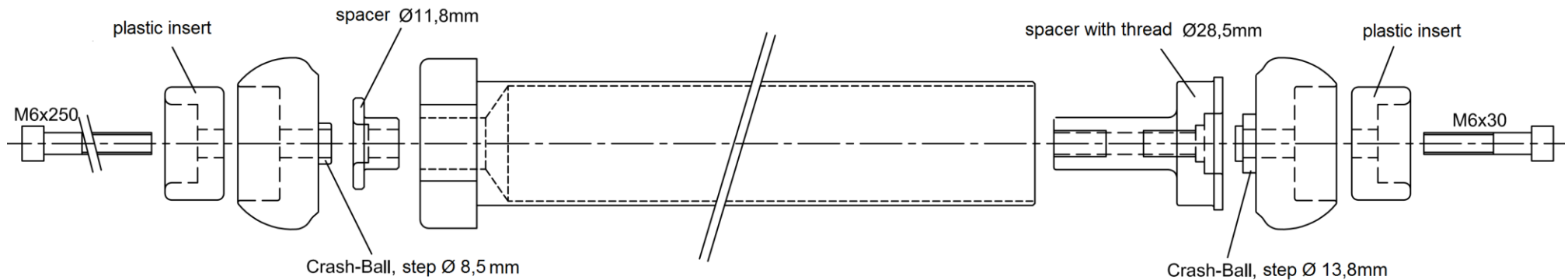

LSL-Motorradtechnik GmbH • D-47809 Krefeld

www.lsl.eu

Stand: 10.05.2007

Important! Montez les Crash Balls à l'axe avant en serrant à un couple de 10Nm. Contrôlez régulièrement le serrage des Crash Balls.

Montage à l'avant gauche

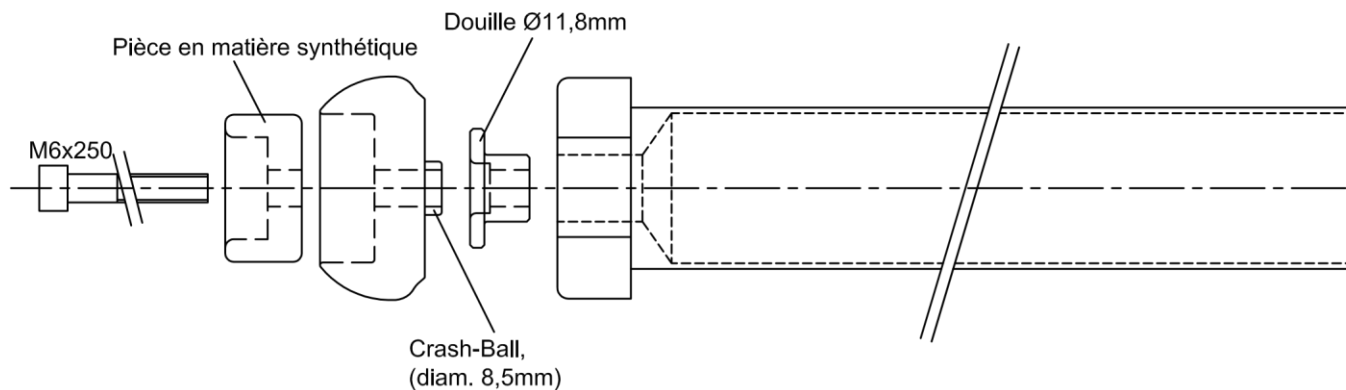

Montage à l'avant droit

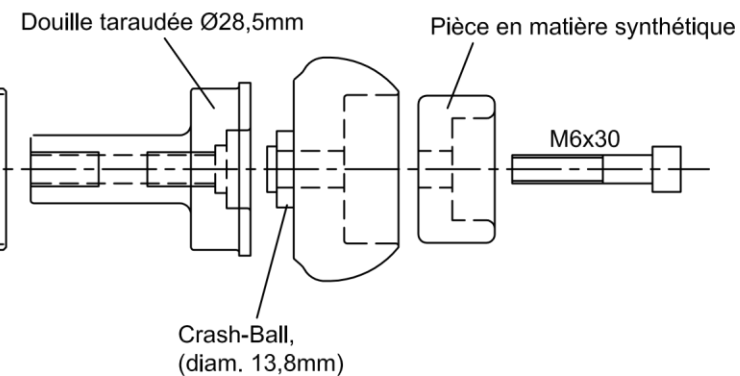

LSL-Motorradtechnik GmbH • D-47809 Krefeld

www.lsl.eu

Stand: 10.05.2007



LSL-Motorradtechnik GmbH • D-47809 Krefeld

www.lsl.eu